

The VELUX logo is a red rectangle with the word "VELUX" in white, bold, sans-serif capital letters. A registered trademark symbol (®) is located at the top right of the word.

# VELUX Modular Skylights

**Designed in cooperation with Foster + Partners**



Front cover: Longlight 5° in The Nemeff Building, Apeldoorn, Netherlands.

Ridgelight 40° fitted with roller blinds in SIEMENS Headquarter, Ballerup, Denmark.

## Bringing light to life with the VELUX Group

More than 70 years of research and development has made the VELUX Group market leader in roof windows. The time has come to use our experience on a bigger scale.

Daylight and fresh air are essential for a healthy indoor environment. Mentally and physically we can perform better with an abundance of daylight and fresh air. This, in combination with solid energy performance remain at the core of the VELUX brand. With the new VELUX Modular

Skylights we now offer these same benefits to commercial buildings. Plenty of daylight, intelligent ventilation and excellent energy performance.

## Reinventing the commercial skylight

Introducing a unique design, a new material and even better energy performance. The new VELUX Modular Skylights are changing the rules of commercial skylights.

VELUX Modular Skylights mark a shift in the evolution of traditional commercial daylighting. For the first time the market is offered a fully prefabricated skylight concept. Made from a composite material that ensures excellent energy performance, thermal stability and high strength

the product is elegantly designed and meets all international standards. VELUX Modular Skylights is an excellent choice for all types of commercial buildings.

# VELUX Modular Skylights

The one module that offer all the benefits of a truly modular system

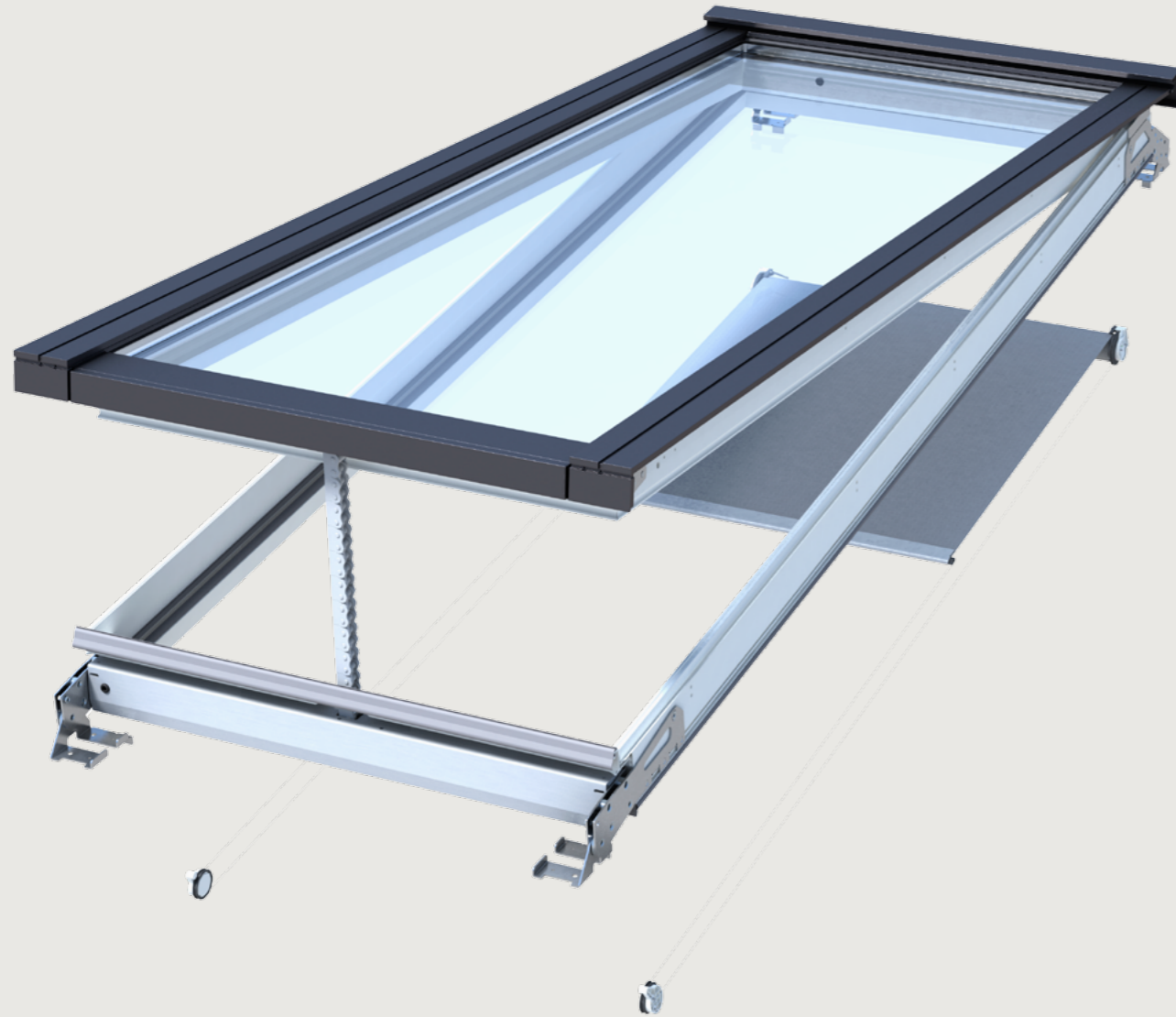

## Index

VELUX Modular Skylights are based on three key advantages

<b>VELUX Modularity</b>	<b>6</b>
<hr/>	
VELUX Modularity sums up the benefits of having a complete product system with 100% prefabricated components, one single module design and an innovative installation principle that ensures fast and easy installation.	▶▶▶
A complete skylight System	8
One module design for all solutions	10
Size grid	11
100% prefabrication for perfect quality control	12
<b>Intelligent Design</b>	<b>14</b>
<hr/>	
Intelligent design equals fully integrated product features and all the benefits of working closely together with the renowned architects, Foster + Partners.	▶▶▶
Designed in cooperation with Foster + Partners	16
Fully integrated ventilation and sunscreening	18
<b>Innovative Material Performance</b>	<b>20</b>
<hr/>	
Material performance is all about maximising the strength, stability and positive insulation properties of the entire installation by employing a composite, which is specifically designed to do the job.	▶▶▶
A new framing material	22
<b>Solutions</b>	<b>24</b>
<hr/>	
Longlight 5 - 25°	26
Ridgelight 25 - 40°	28
Ridgelight at 5° with Beam	30
Northlight 40 - 90°	32
Atrium Longlight / Ridgelight	34
<b>Service and Accessories</b>	<b>36</b>
<hr/>	
Glazing unit	36
Control System	36
Sunscreening	37
Sub-construction	38
A Logical Delivery	40
VELUX guarantee	40
Tools and References	41
On-site VELUX Support	42
Consultancy and Support	43

# VELUX Modularity



Ridgelight 40° in SIEMENS Headquarter, Ballerup, Denmark.

For decades skylights have been designed and installed with components that need to be customized for each specific building's design. Glazing and profiles being delivered on separate pallets, muddled installation procedures that keep the building open to the elements and vulnerable for weeks. It has never been a straightforward task.

VELUX Modular Skylights is an entirely different story. With a fully prefabricated modular concept comes a single module system. All essential components are created, tested and integrated in a controlled environment and pre-fitted prior to delivery.

From an architectural point of view this modular concept comes from a simplified design process where transparency and ease of specification remain keywords.

# VELUX Modularity

A complete skylight system

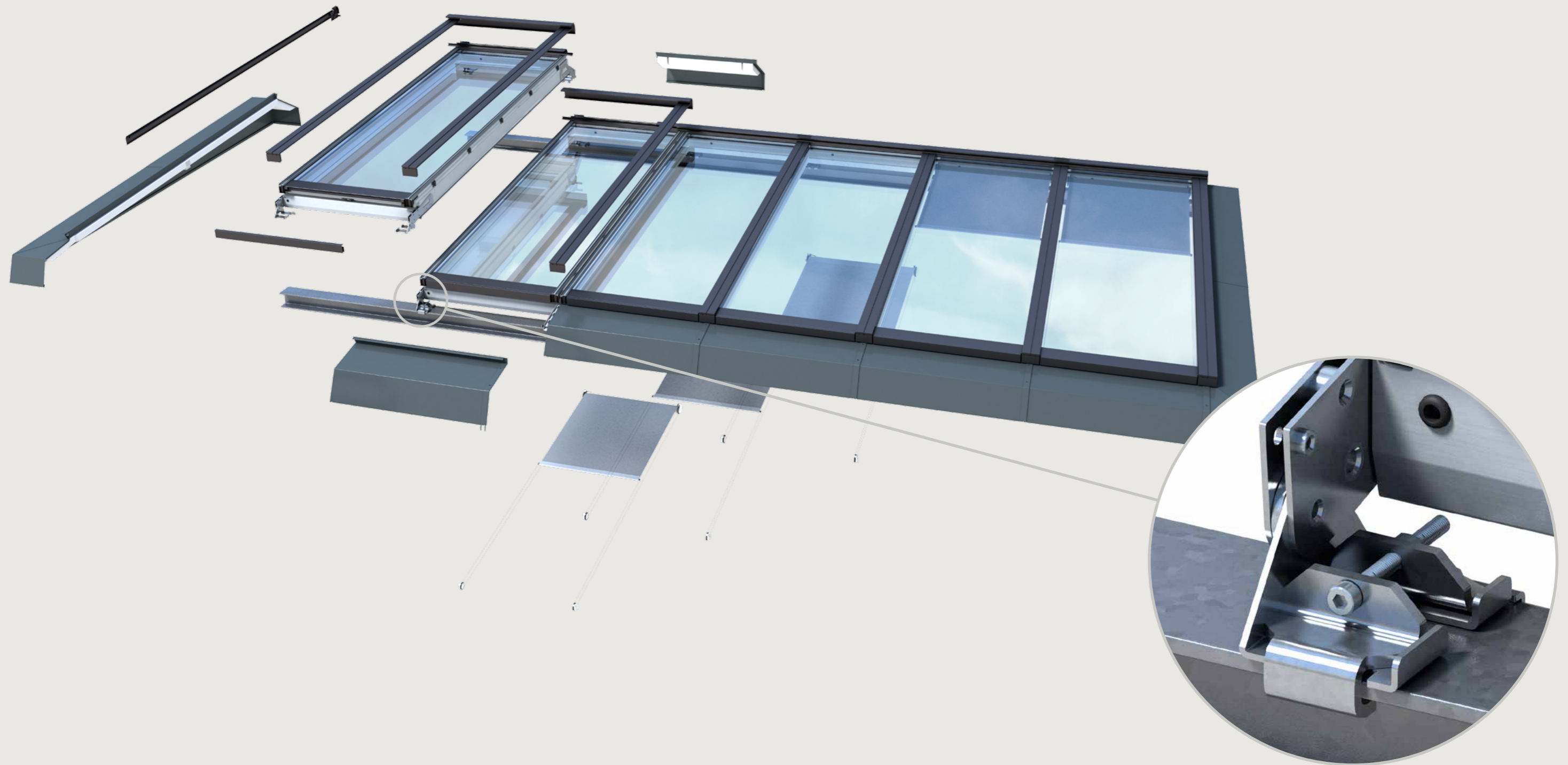

All components are designed in exact accordance to the overall system. In our controlled production facilities we monitor all aspects to ensure a perfect fit and assembly.

A unique bracket system with a simple clamp design guarantees a predictable installation process, this makes it possible to fit an entire module within minutes.

## Benefits

- ▶ High level of functionality
- ▶ Perfect system fit
- ▶ Easy installation

# VELUX Modularity

One module design for all solutions

Longlight 5 - 25°

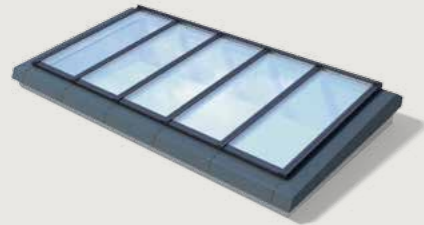

Northlight 40 - 90°



Rigdelight 25 - 40°



Rigdelight at 5° with Beam

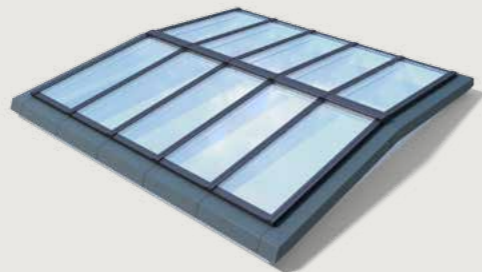

Atrium Longlight 5 - 25°

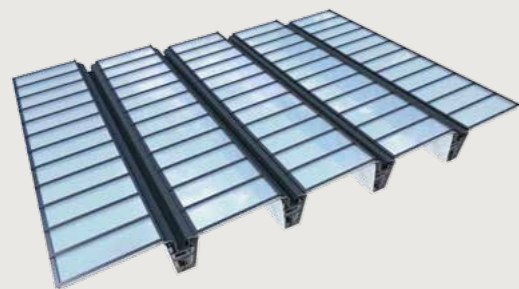

Atrium Ridgelight 25 - 40°

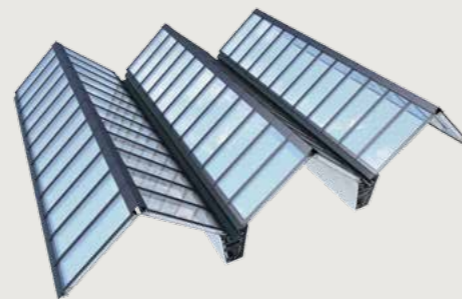

## Fixed modules

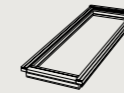

mm	Size grid				
	675	750	800	900	1000
1200					
1400					
1600					
1800					
2000					
2200					
2400					
2600				*	*
2800				*	*
3000					*

\* Extra long modules for longlight and northlight. Constructed with an extra strong glazing unit

## Comfort ventilation



mm	Size grid				
	675	750	800	900	1000
1200					
1400					
1600					
1800					
2000					
2200					
2400					

## Smoke ventilation



mm	Size grid				
	675	750	800	900	1000
1200					
1400					
1600					
1800					
2000				*	
2200			*		
2400		*			

\* Not available with triple glazing

Based on a one-module design specifying the desired solution becomes much simpler, ensuring a safer and more transparent design process.

## Benefits

- ▶ Extensive design options
- ▶ Easy specification

# VELUX Modularity

100% prefabrication for perfect quality control



Tested in Northern Europe's largest wind tunnel with gusts, reaching a full 30 M/S (storm).



Pyrotechnical testing. Glazing unit and profile are able to sustain more than 900° C for at least 30 minutes



Tested for the effect of unwanted electromagnetic fields, interference, radio waves and noise in Northern Europe's only audio centre.

All components used within VELUX Modular Skylights are prefabricated and require no processing on site. Therefore, following installation your

entire solution will replicate the exact properties and safety margins proven throughout rigorous testing in tough conditions.

## Benefit

- ▶ Reliable and predictable quality

# Intelligent Design



Ridgelight 5° in the ATP building, Vordingborg, Denmark – closed modules.

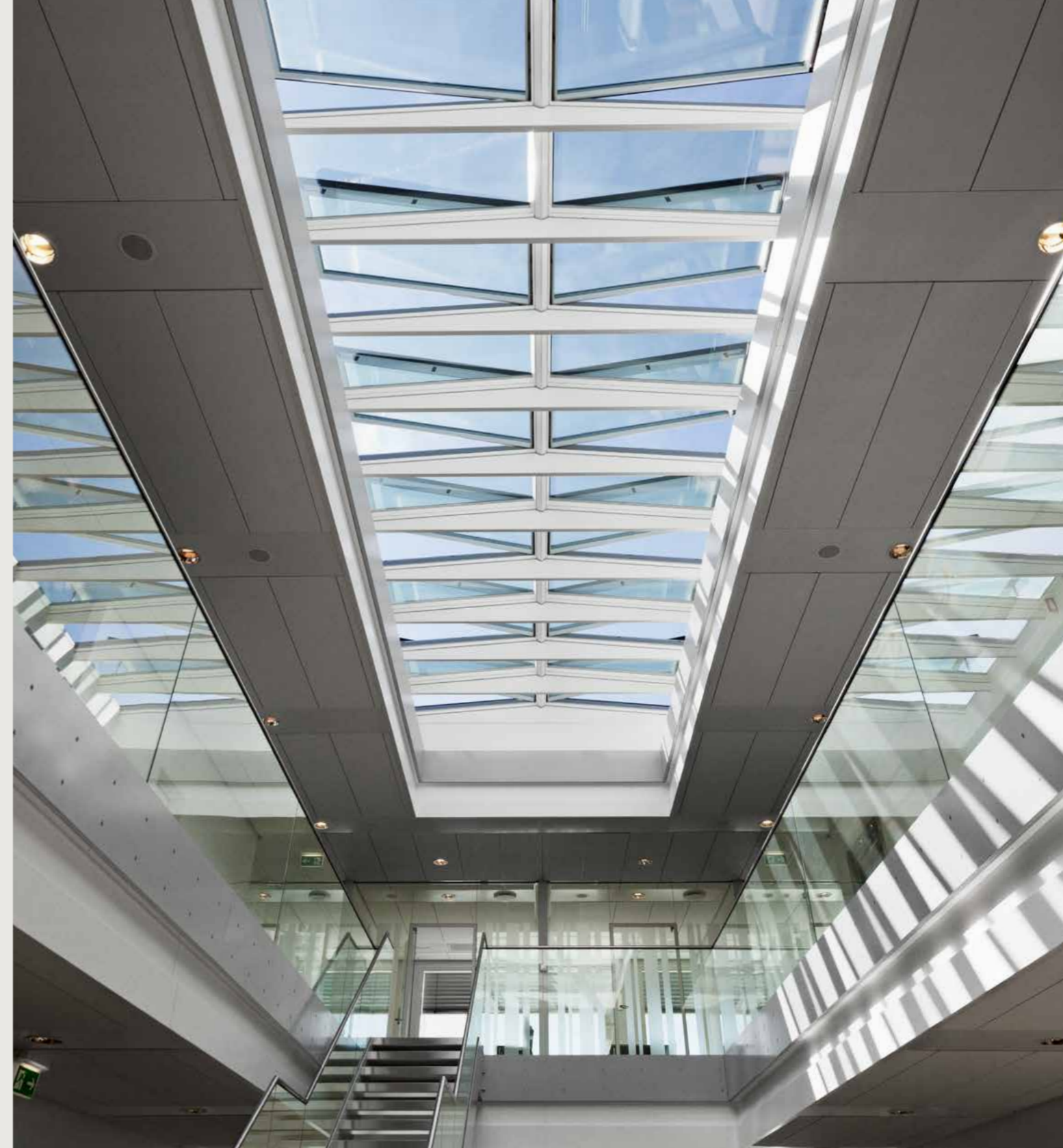

Ridgelight 5° in the ATP building, Vordingborg, Denmark – open modules.

Most contemporary skylights reveal the difficulty of creating a true minimalist design with few obtrusive components. Actuators for ventilation and sunscreening often stick out and spoil the view. VELUX Modular Skylights have overcome this

challenge by creating a totally integrated modular design, inserting actuators into the sash as well as creating a simpler suncreening application. The result is a classic yet modern skylight solution complimenting the overall architectural design.



# Intelligent Design

Designed in cooperation with Foster + Partners



The joint expert team from the two companies used the London Headquarters of Foster + Partners in designing the concept.



Foster + Partners Headquarters



From left: Paul Kalkhoven, senior partner at Foster + Partners and Brent Møller, VELUX architect, at the London Headquarters of Foster + Partners.

VELUX Modular Skylights was developed in close cooperation with the renowned architects from Foster + Partner. Together we have created an intelligent design that meets all international standards and requirements for commercial building.

“ This is our contribution in terms of pushing the prefabrication of sophisticated building elements forward. ”

Paul Kalkhoven  
Senior partner at Fosters + Partners

## Benefit

- ▶ Designed for architecture – engineered for performance

# Intelligent Design

Fully integrated ventilation and sunscreening



1 Slim profiles and a flush exterior surface ensures an elegant look.

2 Chain actuators for venting modules are fully concealed.

3 Internal blinds add to the minimalism with a "floating" design.

4 Ultra small motor hidden inside the blinds.

Ventilation and suncreening components are subtly integrated within the skylight design. Actuators for venting modules and roller blinds are concealed in the slim profiles, meaning there is no visual difference to distinguish between fixed and venting modules.

What you draw is precisely what you get.

## Benefits

► Minimalistic and elegant design

# Material Performance

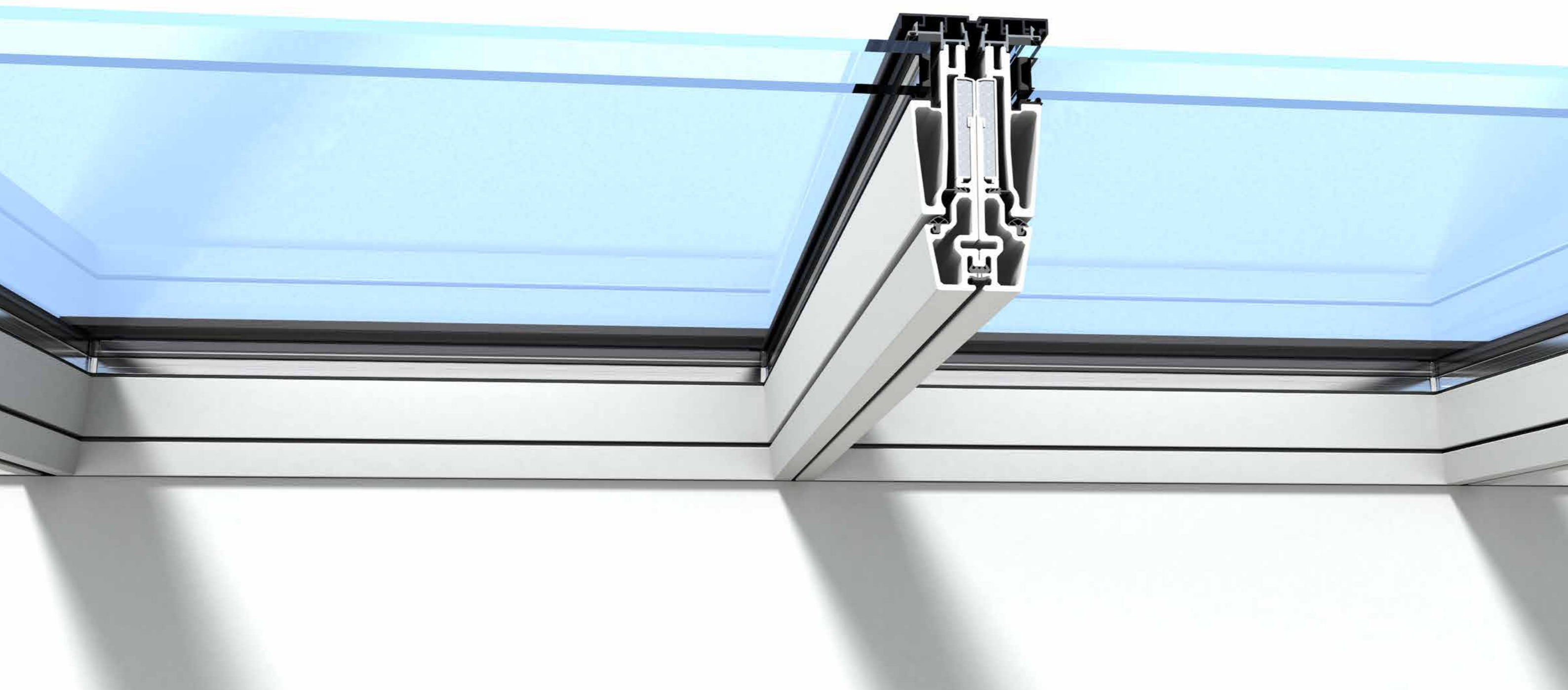

With low-energy glazing units VELUX Modular Skylights offer one of the lowest overall U-values for frame and glazing assembly on the market. 1.4 W/m<sup>2</sup>K with a standard double-glazing unit and only 1.0 W/m<sup>2</sup>K with a standard triple-glazing

unit for both fixed and venting modules. Furthermore, a life-cycle assessment shows that VELUX Modular Skylights offer a better environmental profile than traditional aluminium skylights, due to a better overall energy performance.

# Material Performance

A new framing material made from pultruded fibreglass and polyurethane

## 1 Thermal conductivity (W/mk) - A low score means high insulation performance

Profiles used for VELUX Modular Skylights consist of an extremely low-conductive pultruded fibreglass and polyurethane composite.

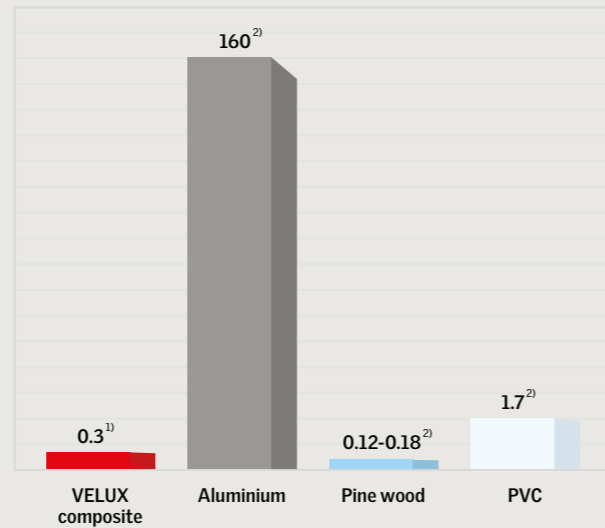

## 2 Linear expansion coefficient (10<sup>-6</sup> m/m K) - A low score means high thermal stability

Whereas traditional skylight materials are bound to change form due to thermal fluctuations, the composite of VELUX Modular Skylights will maintain its dimensional properties, prolonging the expected lifetime of the application.

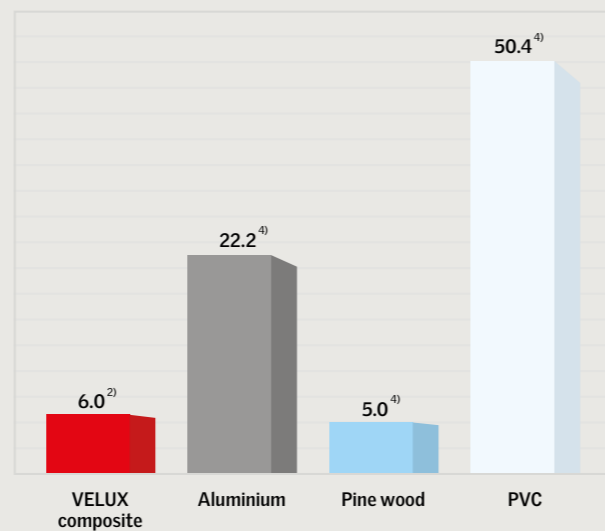

## 3 E-Modulus (GPa) - A high score means high strength

Material that combines low-conductive properties with high strength is usually hard to achieve. Thanks to the nature of the VELUX composite we are able to combine the two characteristics, giving the slim profiles self supporting strength and an ability to support installations of considerable size.

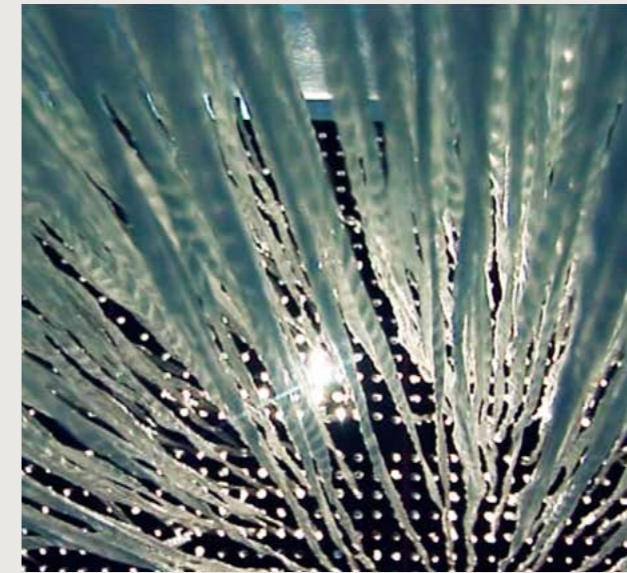
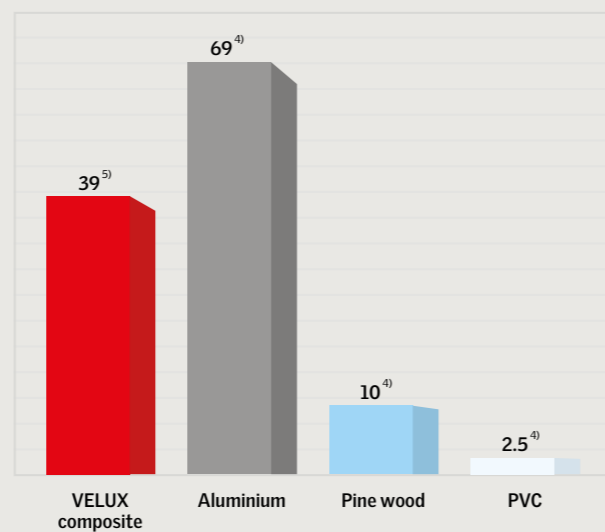

Profiles use composite made of 80% fibreglass and 20% polyurethane.

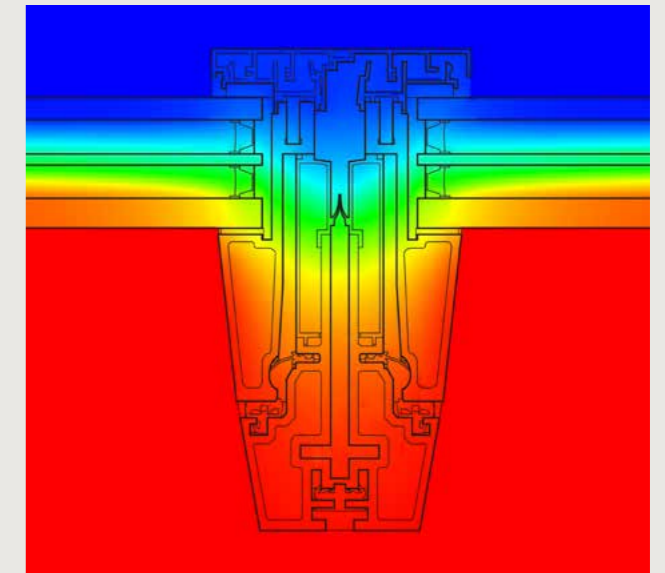

Thermal tests reveal the composite's superior insulating properties.



A pultrusion process moulds the composite and creates an exact form.

## Benefit

- ▶ VELUX composite - a material ideal for skylight profiles

Source: <sup>1)</sup> Approved external test institute <sup>2)</sup> According to EN ISO 10077-2 <sup>3)</sup> Value identical to fibreglass <sup>4)</sup> www.engineeringtoolbox.com <sup>5)</sup> Internal VELUX test

# Solutions

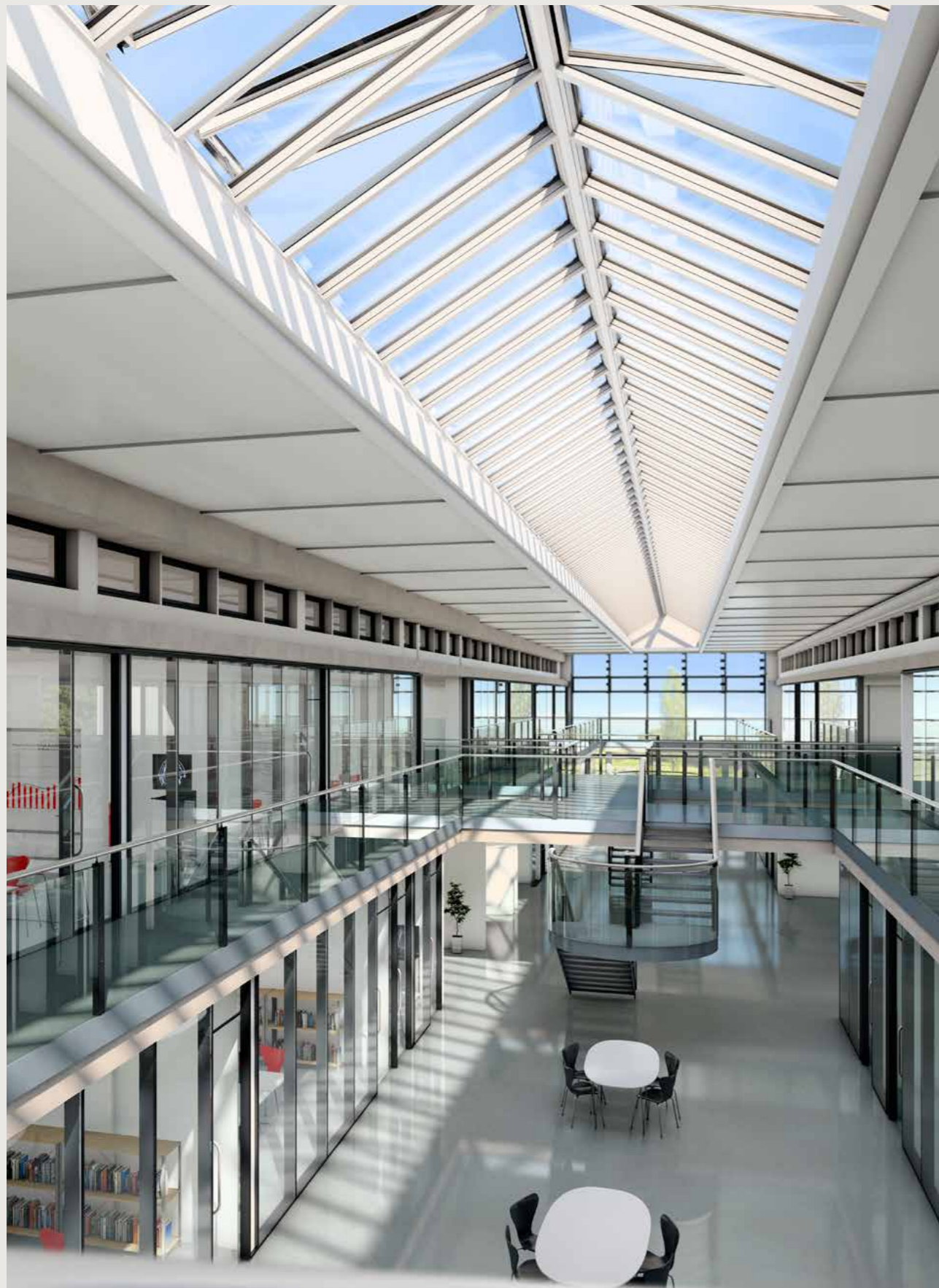

Ridgelight 25 - 40°.



Longlight 5 - 25°.

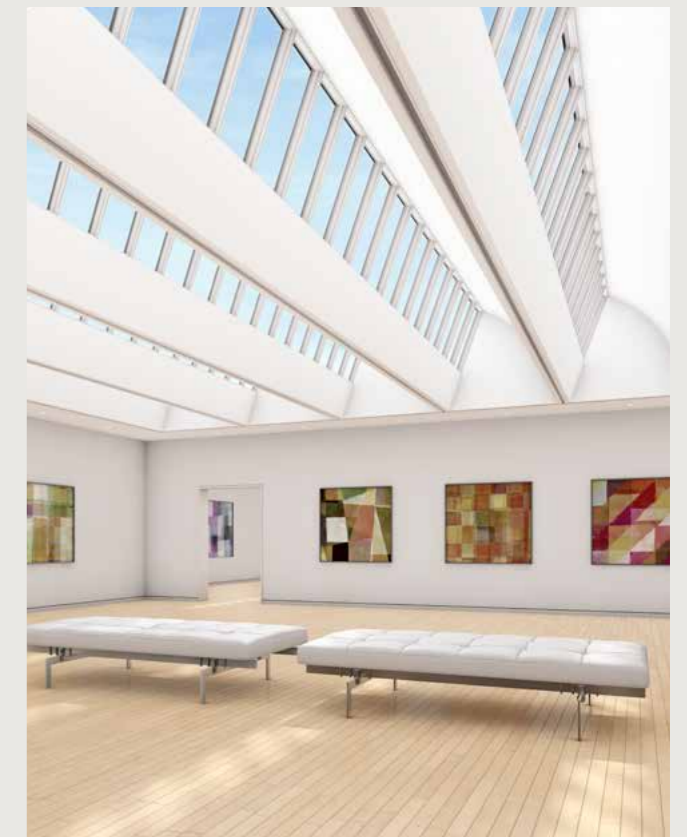

Northlight 40 - 90°.



Ridgelight at 5° with Beam.



Atrium Longlight 5 - 25°.

# Longlight 5 - 25°

Longlights are bands of VELUX Modular Skylights, pre-fitted with installation brackets and clamps that guarantee a fast and secure installation. The flashing allows for configurations with a pitch of 5 to 25°.

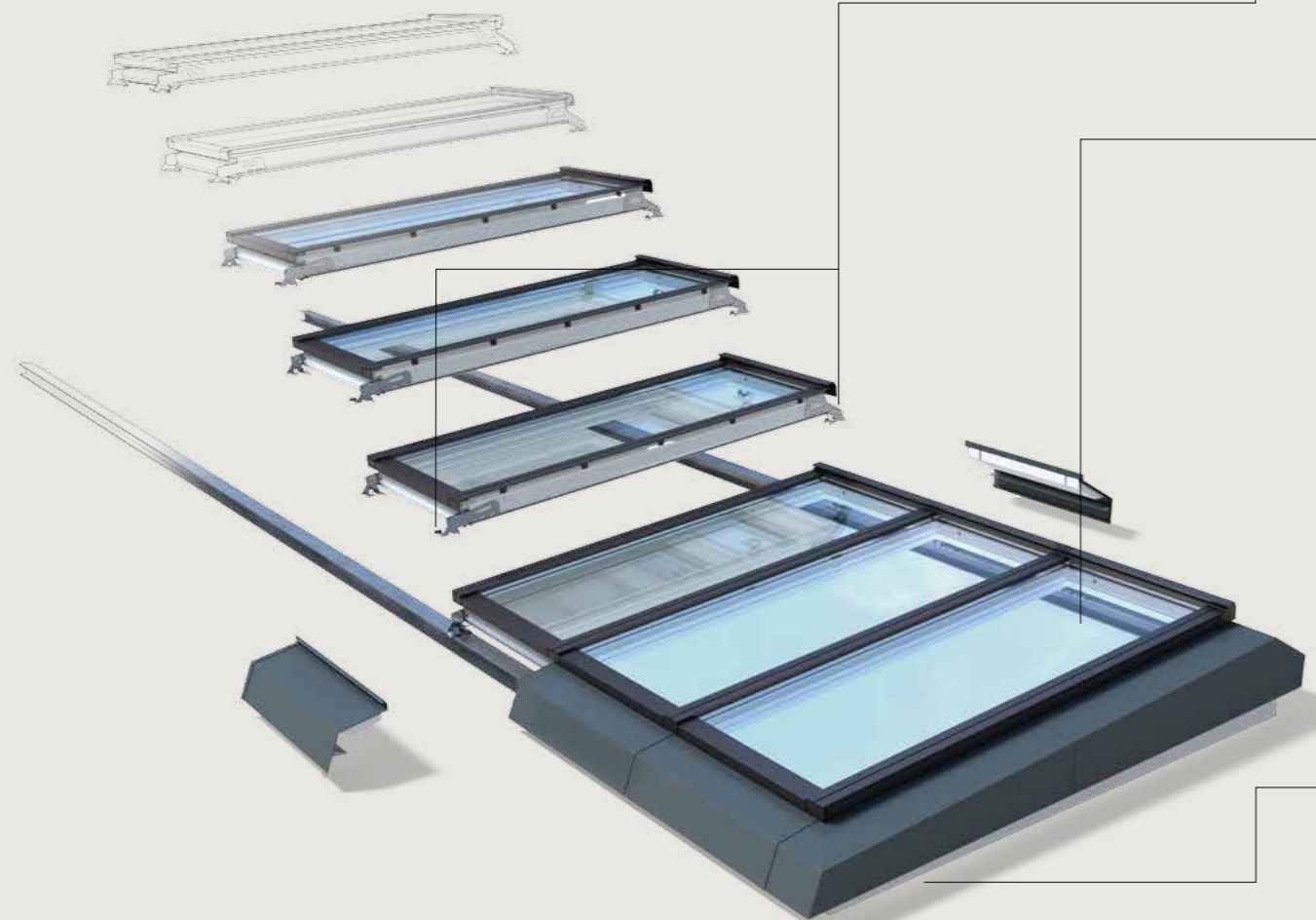

## 1 Mounting bracket

The galvanized steel bracket system for fastening the module consists of two identical brackets and clamps in top and bottom, ensuring a precise and easy installation.



## 2 Down to 5° pitch

The design permits installations down to a 5° pitch. Using fixed as well as venting modules.

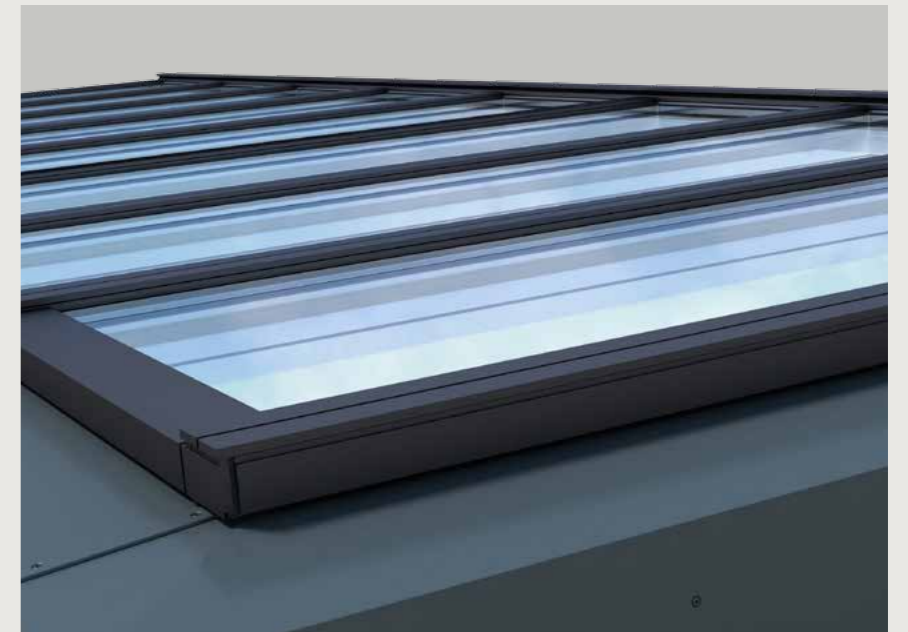

## 3 Modular flashing

The prefabricated modular flashing comes with integrated insulation and snow stop. The flashing is easy to install and guarantees a perfect fit that makes it 100% waterproof.

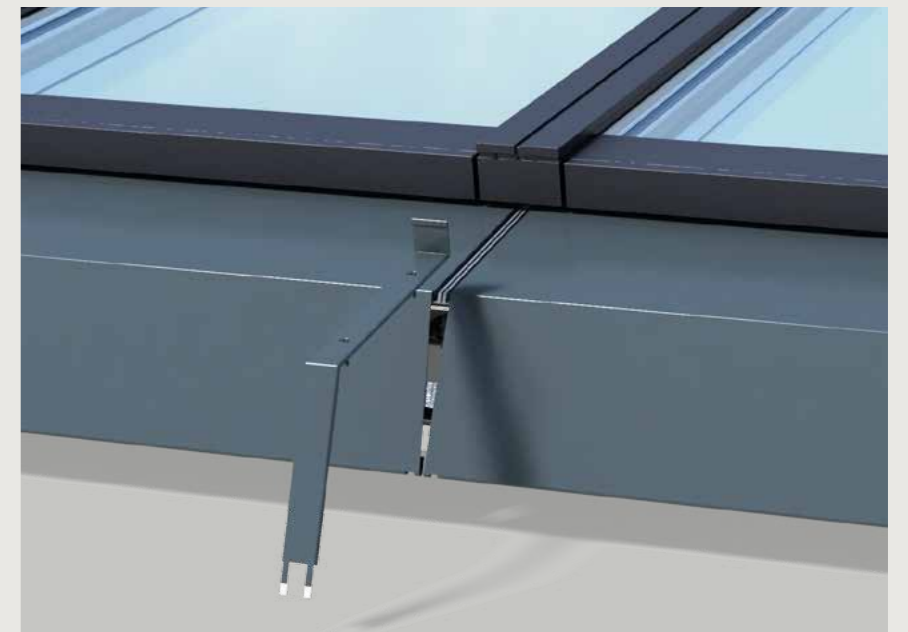

# Ridgelight 25 - 40°

Ridgelight, with a 25 - 40° pitch, is a classic looking solution, consisting of two rows of skylights that support each other. No beam is required as the construction is a self-supporting structure. The flashing allows for installations with a 25 - 40° pitch.

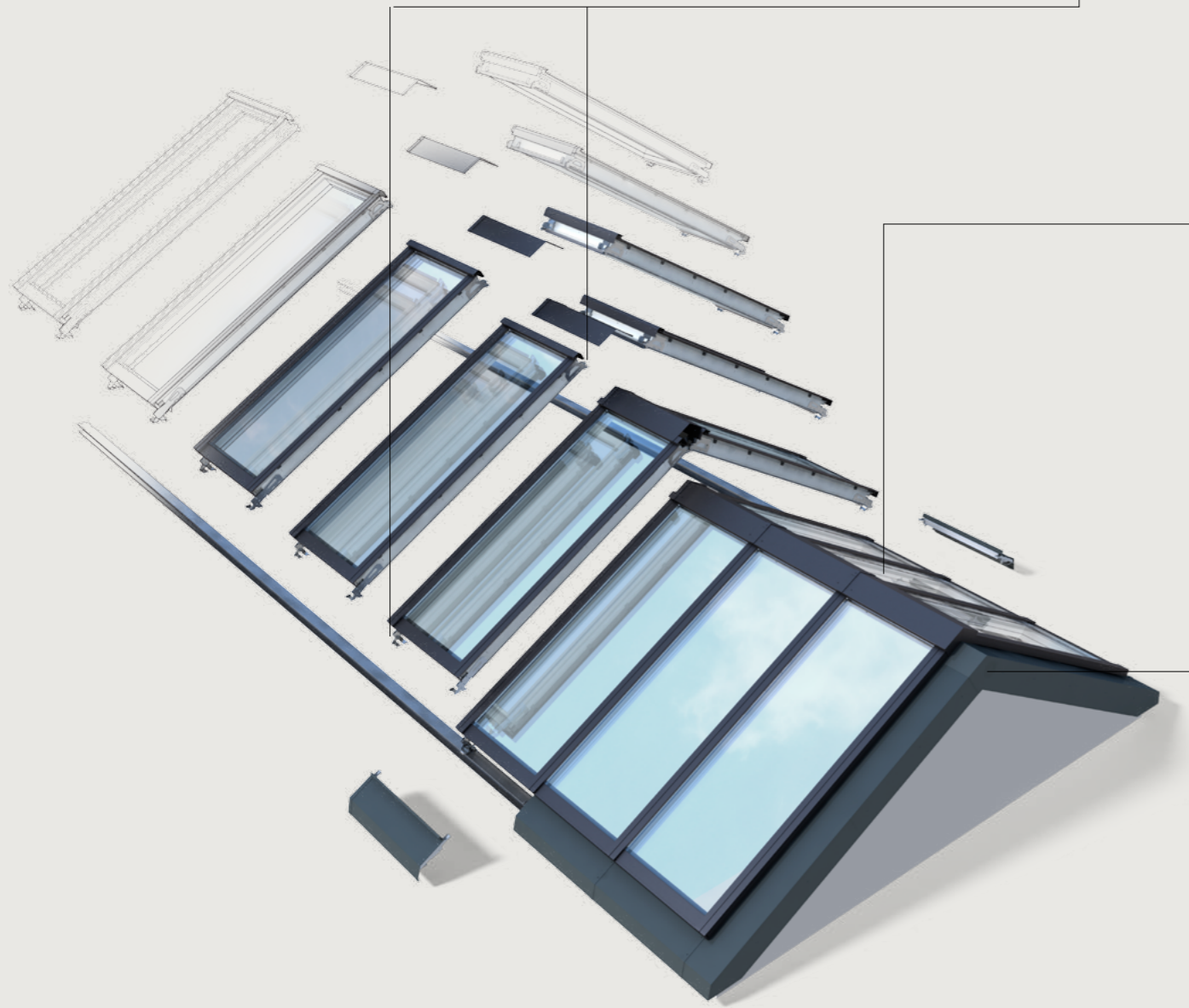

## 1 Mounting bracket

The galvanized steel mounting bracket at the bottom and the interlocking ridge bracket at the top ensures a precise and easy installation

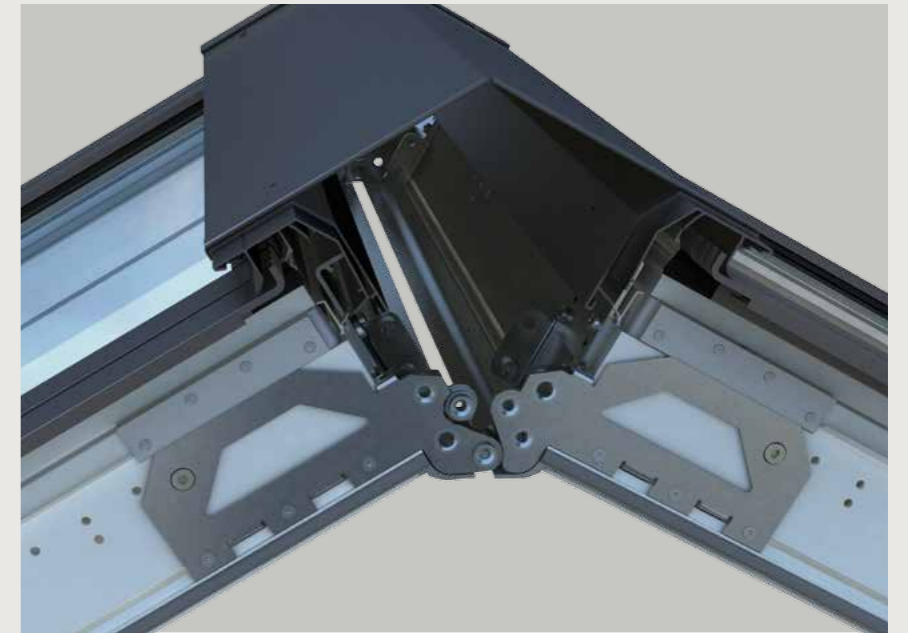

## 2 Self-supporting ridge

The self-supporting ridge is covered internally by a white cover that offers an elegant finish.



## 3 No on-site adjustment

The solution-specific ridge flashing is prefabricated and supplied by the VELUX Group. No on-site adjustment is needed.

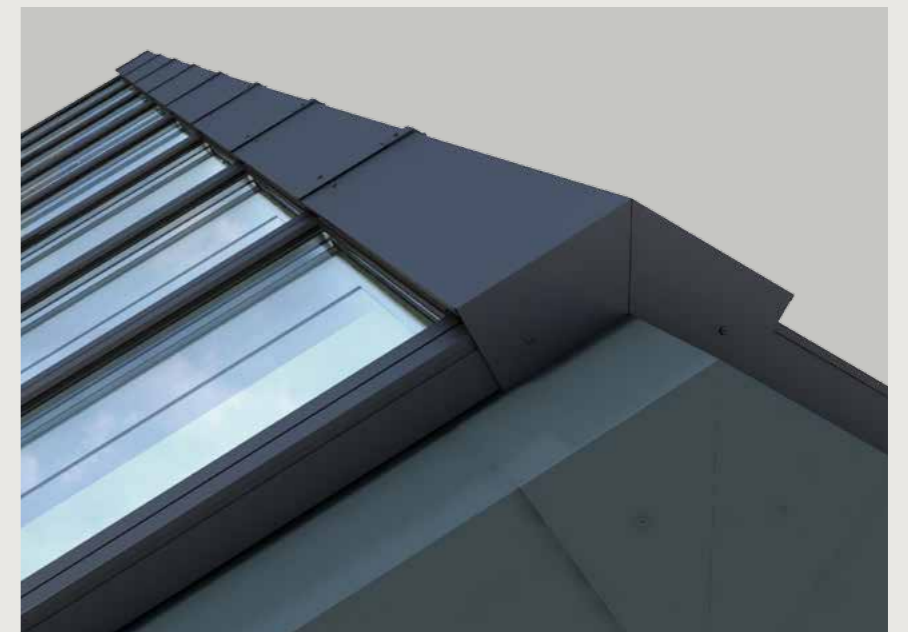

# Ridgelight at 5° with Beam

Ridgelight at 5° pitch generates the illusion of a small glass roof with discreet transverse horizontal supporting beams. Ridgelight is mounted on a rail system that guarantees fast and secure installation.

## 1 Mounting bracket

The galvanized steel mounting bracket at the bottom and the interlocking ridge bracket at the top ensures a precise and easy installation.

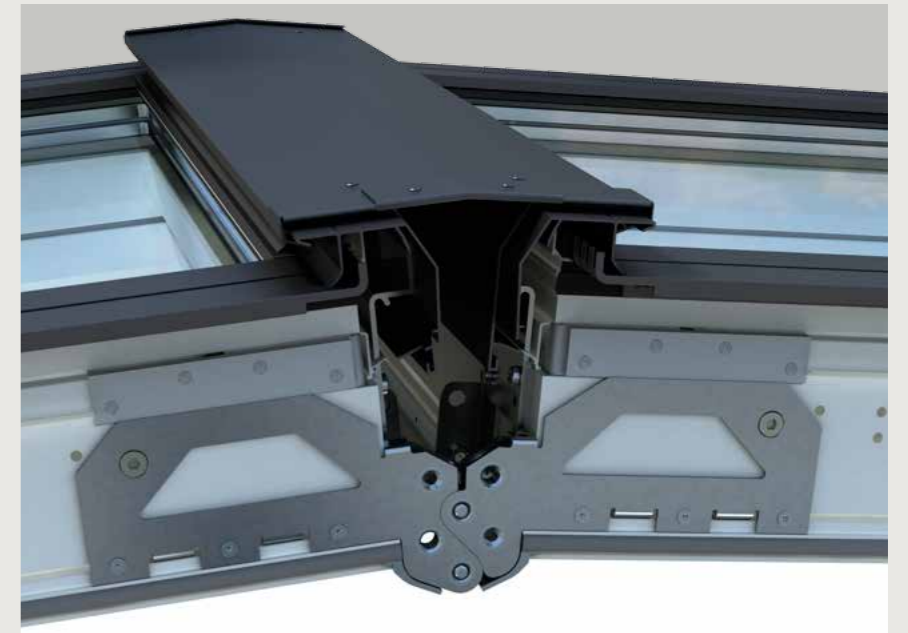

## 2 Supporting beam

The prefabricated VELUX beams support the modules and create a 5° pitch. The beams are mounted on the sub-construction.



## 3 Flashing

The prefabricated modular flashing comes with integrated insulation. The flashing ensures a 100% waterproof installation and seamless integration between roof material and skylights.

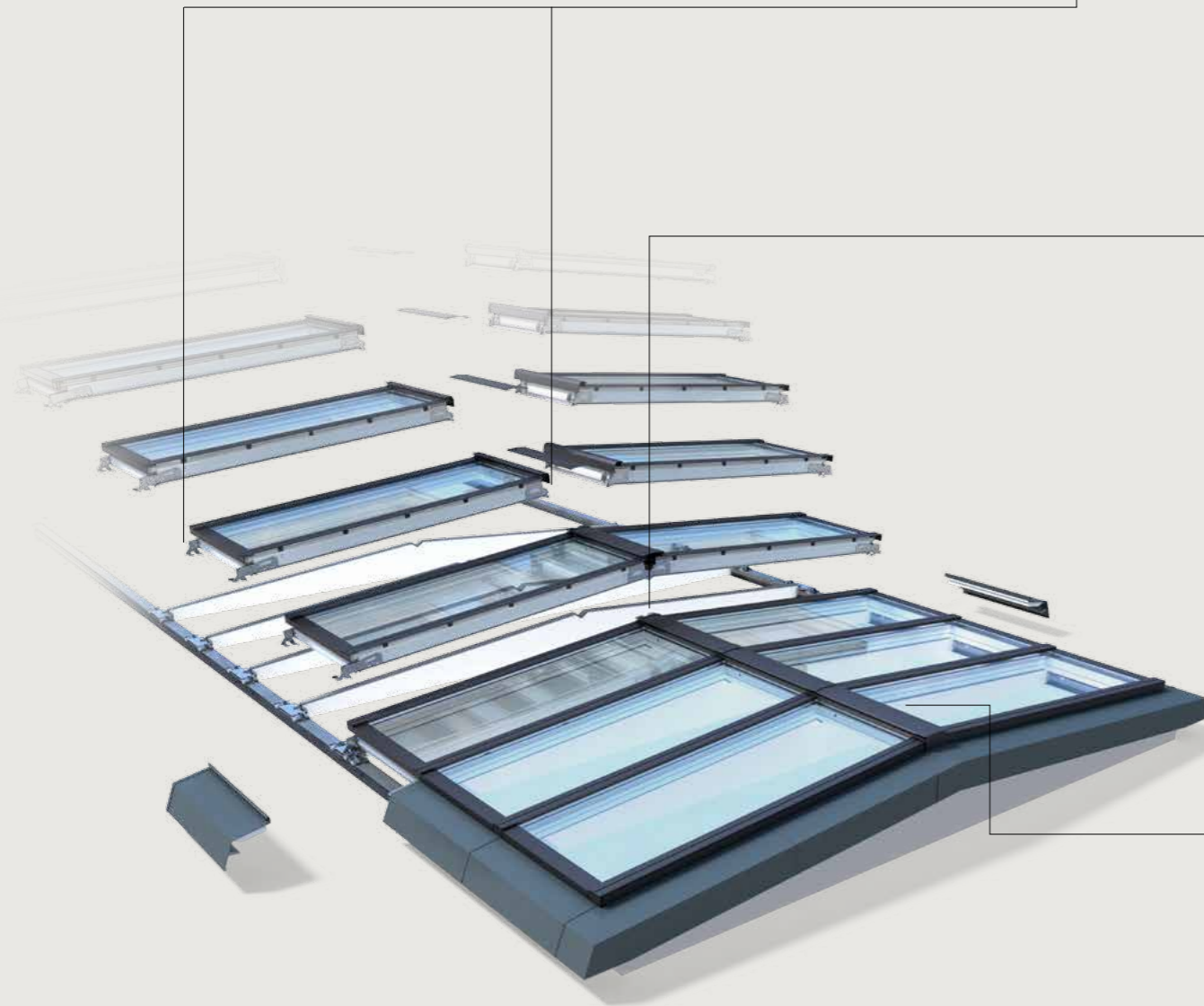



# Northlight 40 - 90°

Similar to longlights, northlights are strips of VELUX Modular Skylights. The characteristic upright design is primarily for installations that are directed towards the northern hemisphere for soft and reflected lighting. Northlight installations are applicable for pitches from 40° to 90°.

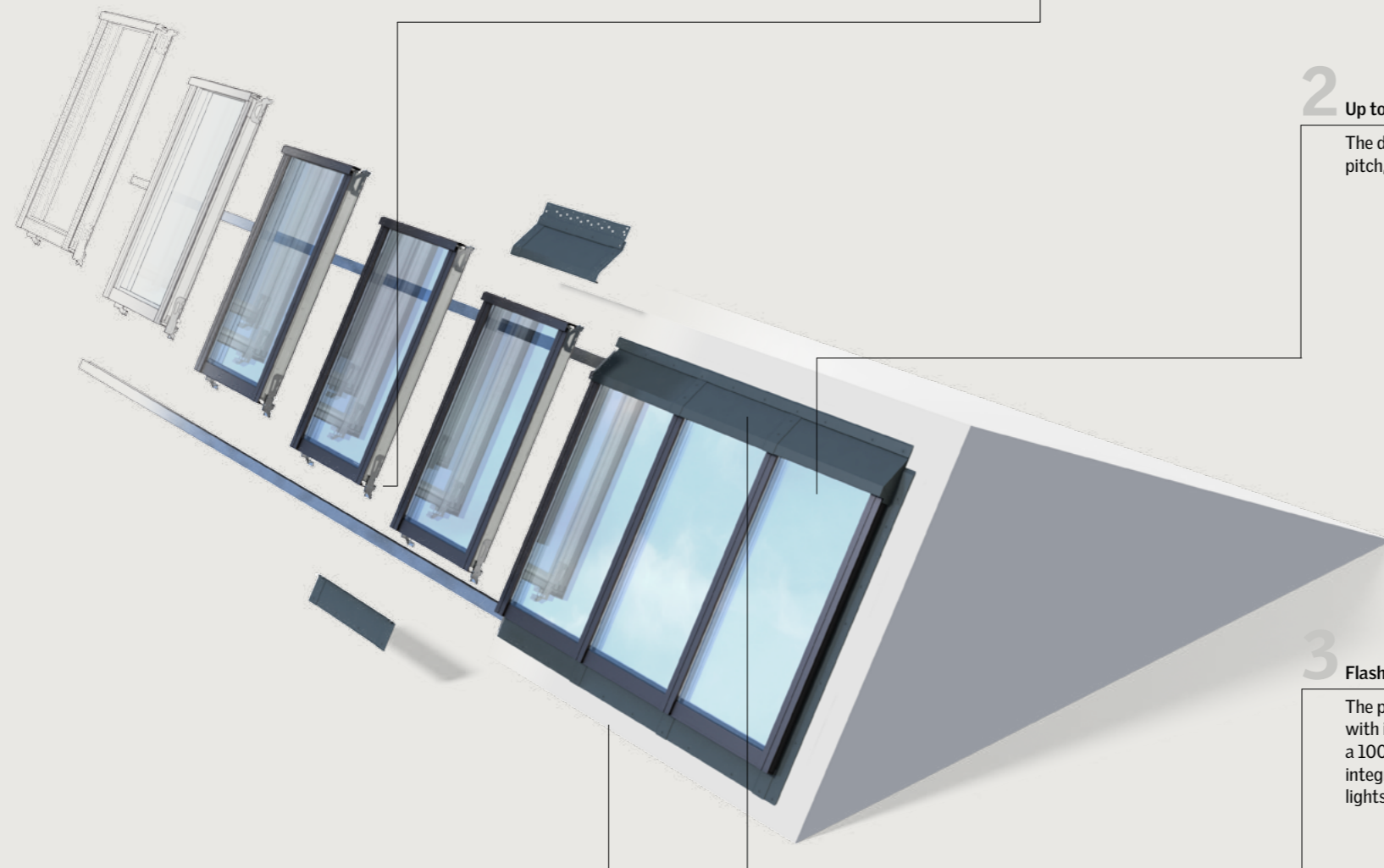

## 1 Mounting bracket

The galvanized steel bracket system for fastening the module consists of two identical brackets and clamps in top and bottom, ensuring a precise and easy installation.

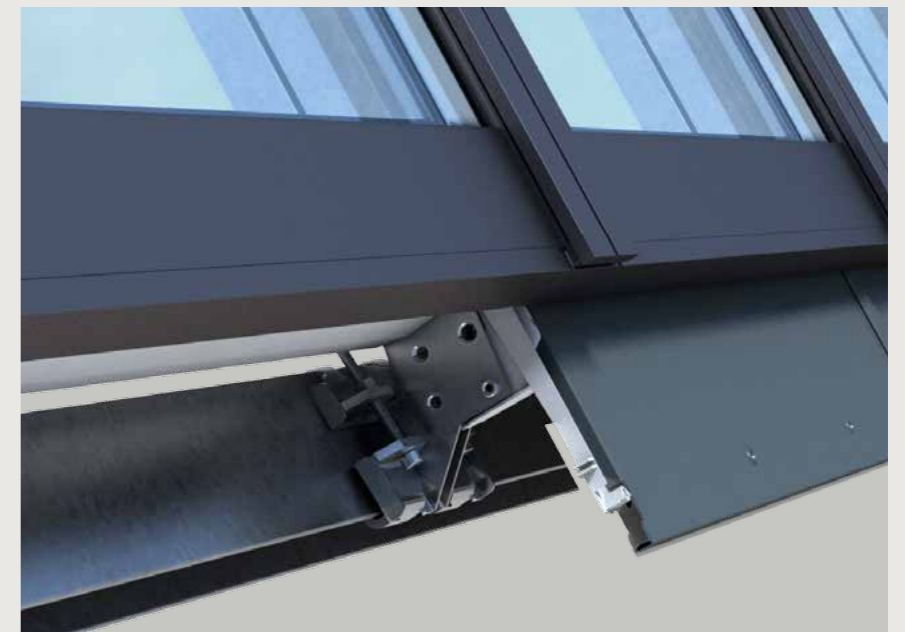

## 2 Up to 90° pitch

The design permits installations up to 90° pitch, using fixed as well as venting skylights.

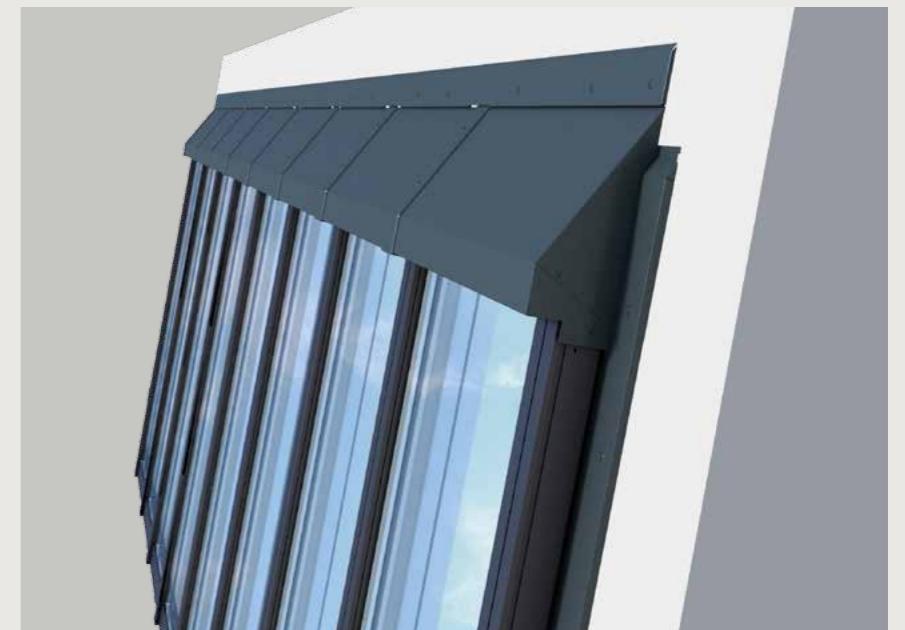

## 3 Flashing

The prefabricated modular flashing comes with integrated insulation. The flashing ensures a 100% waterproof installation and seamless integration between roof material and skylights.



# Atrium Longlight / Ridgelight

An atrium solution consists of several longlights or ridgelights attached to each other in the sub-construction. A drainage gutter separates each strip.

The supporting steel beams are not included in the VELUX delivery. The support structure must be designed by a structural engineer specifically for each project.

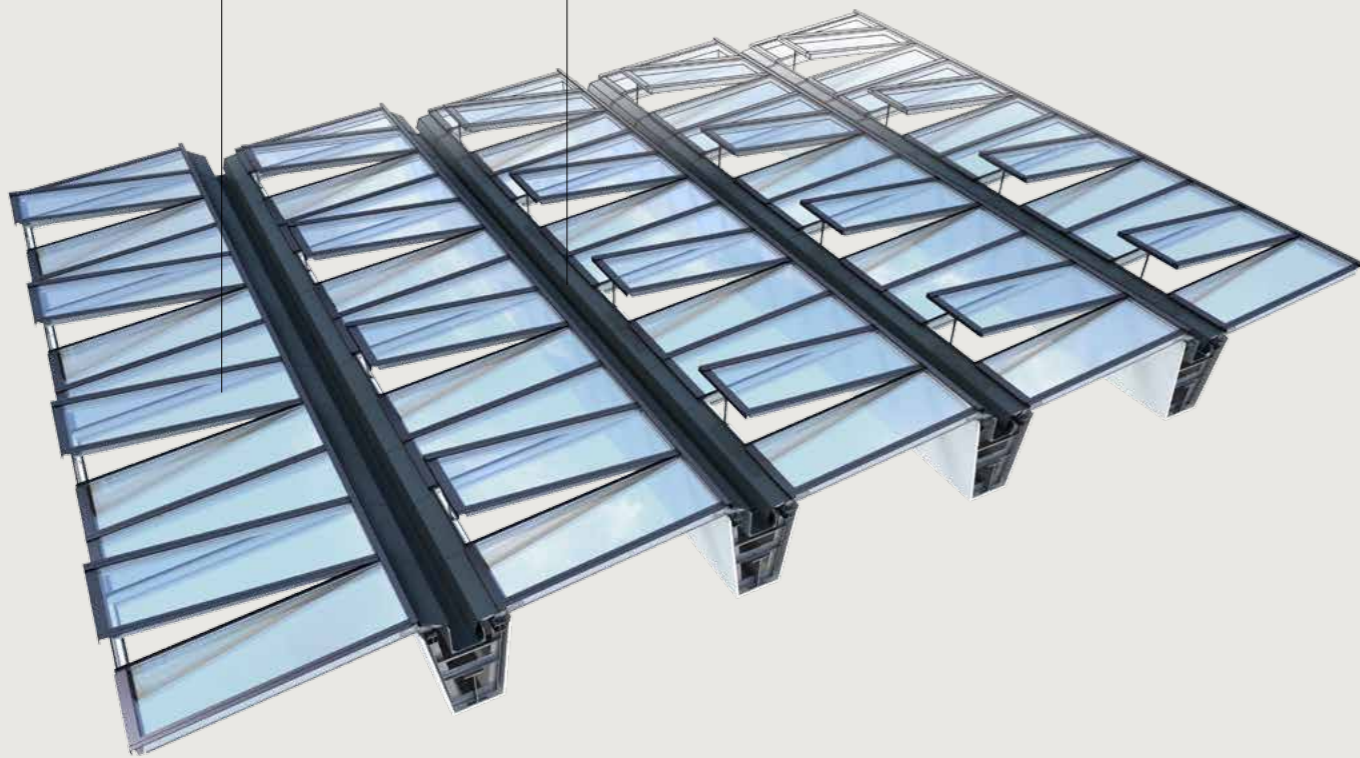

## 1 Full functionality

Atrium brings together all VELUX indoor climate functionalities, including automated ventilation and internal blind control.



## 2 Maintenance

The valley gutter, separating the bands of skylights, offers easy access for external service and cleaning.



### Atrium Ridgelight

An atrium ridgelight is applicable in building designs that have a relatively wide span between transverse beams.

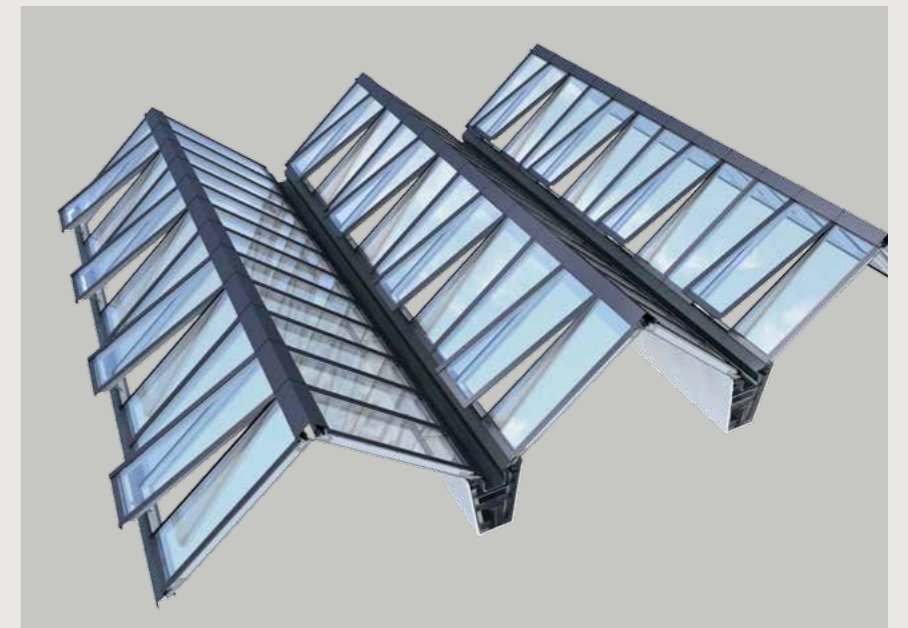

# Glazing unit

Three different glazing options for optimal energy performance

VELUX Modular Skylights come with a standard low-energy double-glazing unit. Alternatively the skylight can be supplied with a glazing unit with improved solar protection or a triple-glazing unit for extra-low U-value.

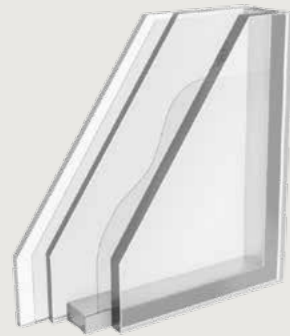

Double-glazing unit

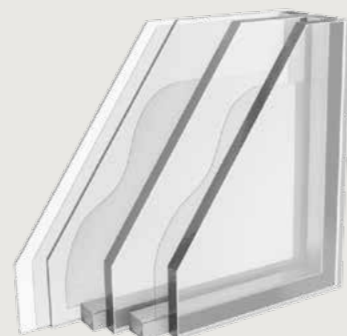

Triple-glazing unit

# Control System

Choose between VELUX INTEGRA® or open system

Venting Modular Skylights and blinds controlled with the VELUX INTEGRA® system will be powered and controlled from a VELUX control unit using the VELUX INTEGRA® control pad, which allow the skylight modules and blinds to be set in any position and offers a range of programming features.

Venting Modular Skylights and blinds controlled with the open system solution is connected to ± 24 V DC and can be connected to, and integrated in, common building automation fieldbus systems.



A wall switch is for basic control of blinds and ventilation.



A combined rain and wind sensor is available as an accessory.



**io** homecontrol provides advanced and secure radio technology that is easy to install. io-homecontrol labelled products communicate with each other, improving comfort, security and energy savings. [www.io-homecontrol.com](http://www.io-homecontrol.com)

The VELUX INTEGRA® control pad offers fully automated control.

# Sunscreening

Blinds help control the indoor climate



Blinds can be drawn to offer heat and glare protection, whilst the venting modules remain fully operable.

The internal roller blind is designed for installation with VELUX Modular Skylights. The blind offers protection against heat and glare and is available in three commonly used colours. The fabric is colourfast and very durable. All brackets and wheels are grey.

Sunscreening

Fire resistant

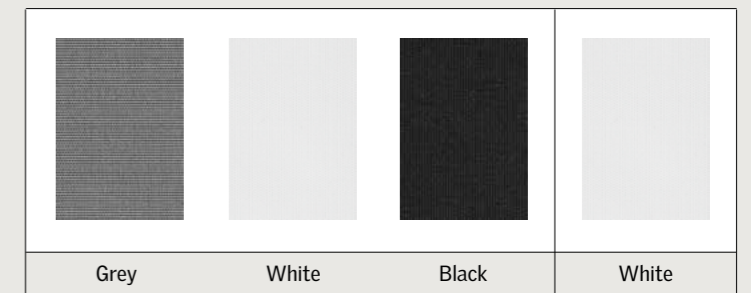

# Sub-construction

An accurate sub-construction precedes a trouble-free installation

To achieve a trouble-free installation process the sub-construction needs to accommodate the unique module installation system. VELUX Modular Skylights require an accurate fixed dimensioned substructure. Likewise the strength of the sub-construction needs to be calculated from project to project, based on the building design and application size. Hence the sub-construction is not part of the prefabricated modular system.

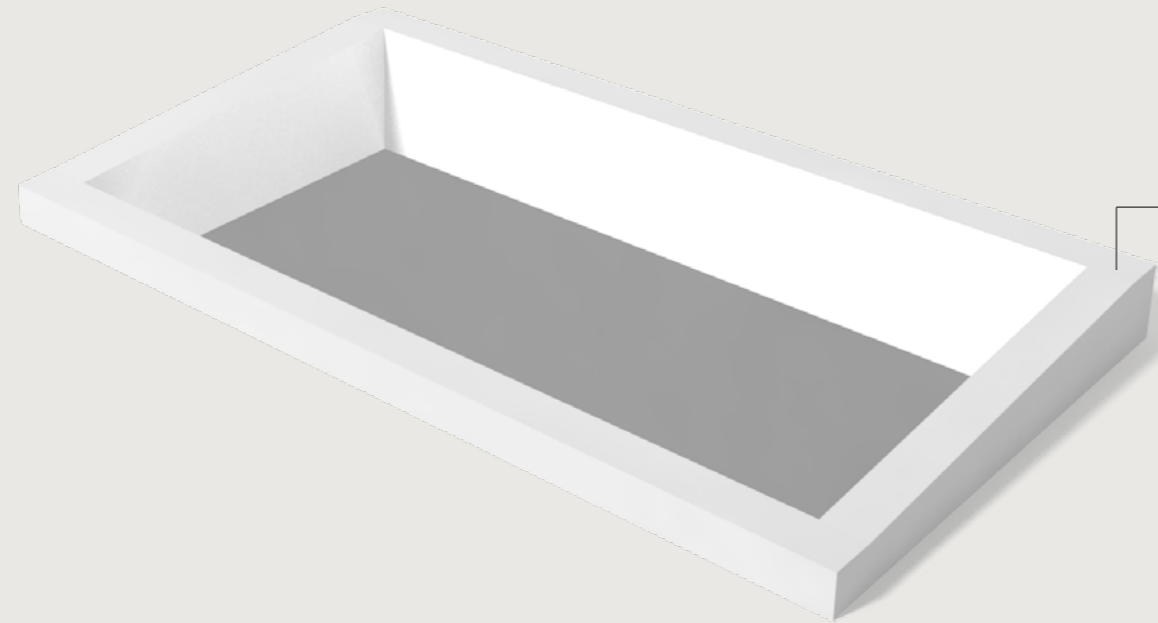

## 1 Timber

Timber remains the most flexible choice for creating a light and economical sub-construction with maximum energy performance. Due to its limited strength timber is not recommended for larger solutions and ridgetight installations.



## 2 Steel

Steel offers flexibility in combination with great strength. Steel also permits the application to be installed with the maximum amount of insulation.



## 3 Concrete

Concrete provides a strong, but heavy sub-construction, mostly suited for concrete buildings. Whereas a wood or steel sub-construction can be prefabricated and hoisted onto the roof, concrete upstands are usually cast in-situ.

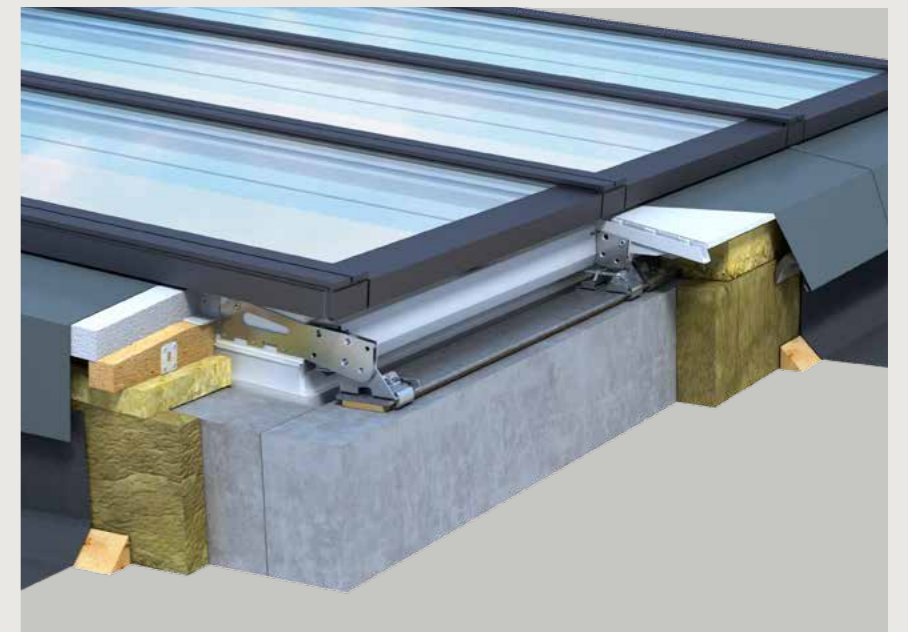

# A Logical Delivery

All elements are labelled for logistical control and building optimization



On delivery each pallet is clearly marked with a letter, signifying the components ranking in the installation process. The letters make it easy to arrange

the delivery on arrival and plan the following installation, so that each component is made available at the right time at the right location.

# VELUX Guarantee

VELUX Modular Skylights are supported by a 10-year guarantee

VELUX Modular Skylights and VELUX flashings are supported by a 10-year guarantee. Blinds, actuators and other electrical components that are a part of the modular system comes with a 3-year guarantee.

All warranty is subject to correct installation and usage. Warranty conditions can be found on: [www.modularskylights.velux.com](http://www.modularskylights.velux.com)



# Tools and References

Take a look at our professional tools and references on [velux.co.uk/modularskylights](http://velux.co.uk/modularskylights)

## Website

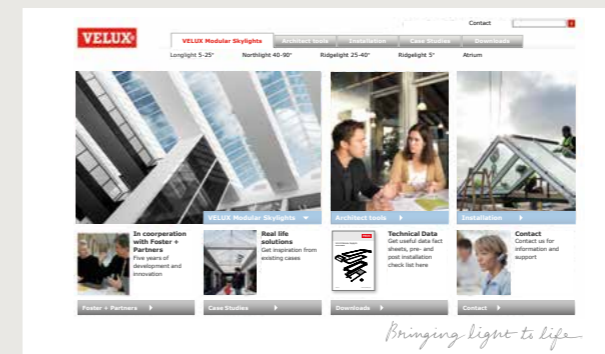

Visit the product website, explore our vast amount of background material and try our professional tools.

## Technical data



All vital data is available in the technical data sheets. Order your free copy or download the sheets directly from the website.

## VELUX Daylight Visualizer

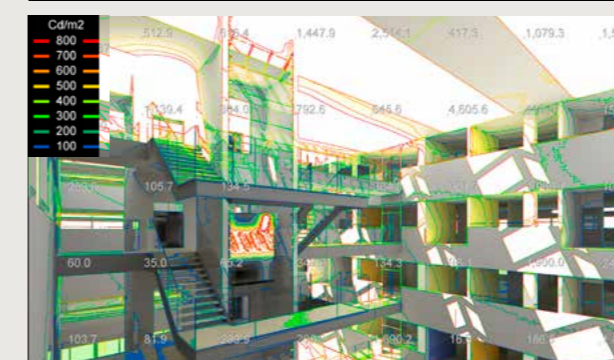

Test the daylight effect of your project in relation to the ecliptic and your chosen application.

## Films



Get the entire vision and product overview in only a few minutes. The film offers a rare look behind the scene at Forster + Partners and uncovers the development process from start to finish.

## Case stories



Explore existing projects and read what architects, builders, installers and end users think of VELUX Modular Skylights.

## CAD and BIM



Visit our website to download valuable professional tools, including CAD, ArchiCAD and Revit elements. Register to receive regular updates.

# On-site VELUX Support

From drawing board to building site



The VELUX Group offers on-site expert support during the entire project. Based on each building case we help to identify the best product and delivery option. All technical documentation is available offline and online for planning, easy specification, design processing etc.

To ensure a trouble-free installation process, we also offer training of commissioned installers, providing them with vital knowledge and the confidence to get the job done in a safe and timely manner. Following installation, we offer comprehensive after sales support by way of; user guidance, product maintenance and timely solution updates.

# Consultancy and Support

Contact VELUX Modular Skylights for more information and support

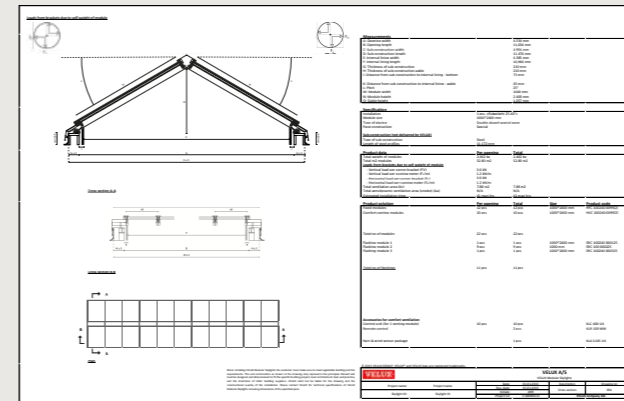

Our experts will help you identify the best and most viable solution.



Contact us for more information.

Address: Woodside Way, Glenrothes, Fife, KY7 4ND  
 Tel: 01592 778 916  
 Email: vms@velux.co.uk

VELUX Company Ltd  
Woodside Way  
Glenrothes  
Fife  
KY7 4ND  
Tel: 01592 778 916  
Email: vms@velux.co.uk

*Bringing light to life*™

**VELUX®**